

Technical leaflet 150052 0	Date 2011-06-15
-------------------------------	--------------------

SiloSafe

Cartridge Filter



The SiloSafe 24 design is based upon years of experience selling and servicing silo venting filters, hours of discussions with silo manufacturers and meetings with silo purchasers and cement silo operators.

The SiloSafe 24 is suitable for use with ATEX certified vessels handling potentially explosible dust. Design reduced explosion pressure = 0.75bar. (Test Pred = 1.35bar).

Filter cartridges are made of thermally bonded pleated polyester tubular cartridges incorporating Uniclean individual cartridge filter area of 4m². Standard media are CA100 polyester (others available).

Features

- silo venting applications
- cased, reverse jet cleaned cartridge filter, with base mounting flange.
- Hot-dip galvanized finish = long, corrosion free service
- 4mm fully-welded steel construction = strength to stand up to abuse from overfills and over pressure
- 24m² = enough filter area to handle virtually all materials delivered pneumatically to silos.
- Low profile and top-removal cartridges = safe maintenance
- patented Uniclean cartridges = enhanced cleaning, higher efficiency and longer cartridge life
- Lower spares prices (only 6 cartridges). Re-fitting cartridges is less than half the price of some comparable filters.



SiloSafe
Planning-in Data

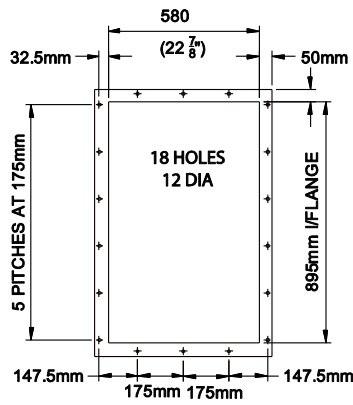

FILTER MATING FLANGE DETAILS

SiloSafe 24

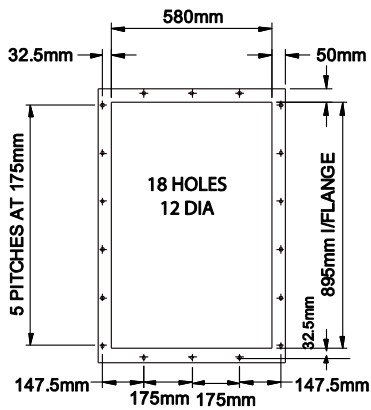
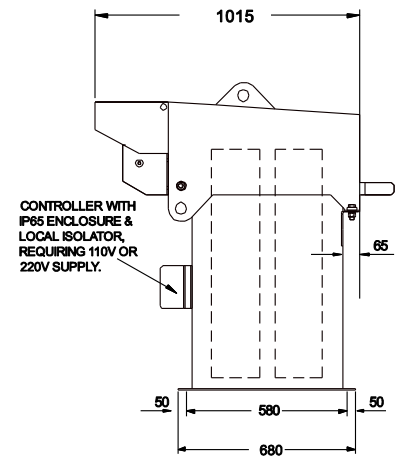
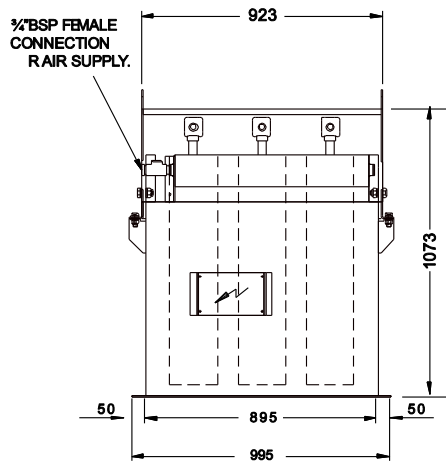

FILTER MATING FLANGE DETAILS

SiloSafe 24 F

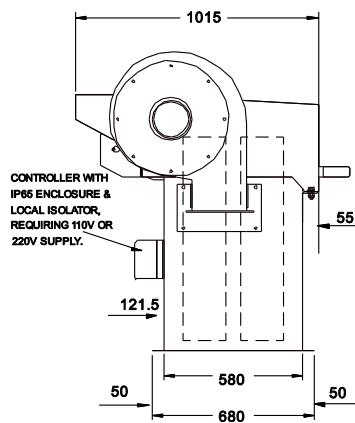
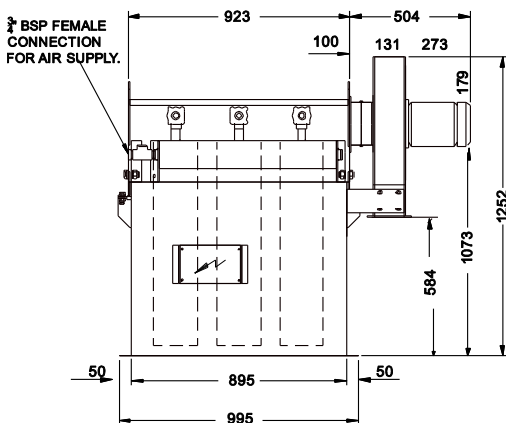

Cartridge Material

At the heart of every MJC cartridge filter is the UniClean Patent pleated cartridge element.

The overall dimensions, including pleat depth and spacing were designed uniquely for the MJC range and its smaller sisters MJCMini and SiloSafe. More than ten years' experience in many applications and the more recent introduction of the UniClean feature ensure maximum performance and long life.

The MJC range uses a Type 40 with 4.0m² or a Type 66 with 6.6m² per element.

Filter materials are:

- CA100 high quality thermal bonded polyester pleated fabric as standard.
- CA140 as CA100 but with metallised antistatic treatment.
- CA190 as CA100 but with ptfe dust release treatment.
- CA175 is 80% cellulose, 20% polyester material available to special Order.

Surface Filtration

The filter media is typically around 1.7mm thick but contains many layers of random fibres. Filtration occurs at or very near the surface of the materials and its efficiency (BIA class U, S, G, and C) may be further enhanced by a surface layer of dust. For light dust loads, or very fine dust, it may be beneficial to pre-coat the filter by introducing used dust, or a special pre-coat material. Please ask for information

SiloSafe Technical Specification

Principal fittings	stainless steel or galvanised
Reverse jet cleaning	single 8.6 litre steel compressed air reservoir
Max. working pressure	7.0 bar
Test pressure	13.0 bar
Normal cleaning pressure for cartridges	5.5 barg
Compressed air consumption (typical)	60 Normal litres per pulse. For standard 10 sec. interval between pulses, this is equivalent to 5.4 Nm ³ /h for continuous operation over typical duty cycle.
Cleaning valves	combination 1" diaphragm / solenoid valves, 110v AC.
Number of cleaning valves	3 Each valve services 2 cartridges.
Reverse jet timer	(typically) 6-way printed circuit board housed in IP65 enclosure
Short circuit protection	1amp circuit board fuse
Fan (SiloSafe 24-fan)	high efficiency backward curved radial fan with 2.2kW, 3 phase induction motor.
Electrical Supply	SiloSafe 24: 110 or 220V Single Phase 50 or 60 Hz; SiloSafe 24-fan: add 380/415V 3-phase supply for 2.2kW fan.
Unit weight	SiloSafe 24 - approx. 125kg; SiloSafe 24-fan approx. 160kg